

AS Combo



Versatile, proven integrated checkweighing and metal detection systems for the food and packaging industries

Loma AS1500/5000

Loma AS1200c

Loma ASHW

Loma ASDL

Loma ASCombo

Summary

Our sales and design engineers work with you to provide a combo system that is suitable to your individual application requirements.

The combo range is the result of over 35 years of expertise in the food processing and packaging industry. Careful design has resulted in a modular product for ease of maintenance and minimum parts stocking requirement.

Loma's checkweighers are enhanced by the performance of a sister company's highly accurate and stable digital loadcell or Fast Intelligent Transducer – FIT, that maintains stability over extremes of temperature and humidity.

An essential part of any combo system is an efficient reject device. Our sales and design engineers will ensure that the most effective device is selected for your individual application.

Loma produce a wide range of robust, reliable and user friendly models to meet industry needs, whether for packaged, bulk-fed or pumped product.

Loma delivers better, consistent quality to your product and plays a vital role in protecting your brand.



Benefits at a glance:

- **Versatile** Weighs a wide range of flexible and rigid packs up to 6kg (13lb)
- **Accurate** Excellent accuracy, especially with flexible packaging
- **Compact** Integrated to save line space
- **Reliable** Heavy duty conveyor components, high quality electronics
- **Accredited** OIML R51 approved
- **Effective** Loma expertise in both technologies ensures maximum system performance

Benefits of Combination Systems

Checkweighers and metal detectors have been used in the food processing and packaging industry for over 30 years so the technology is well tried and tested.

National weight legislation ensures that manufacturers comply with weight requirements for the goods that they are producing. Lack of compliance can lead to prosecution. An automatic checkweigher not only inspects every pack but produces records to demonstrate compliance. Most weight legislation is concerned with the production of underweight goods. However, a checkweigher can control the production of over-weight goods and in so doing reduce give-away, this enhances profitability. Some applications (such as tea and coffee production) offer the opportunity of enhancing profitability further by applying servo feedback control to the volumetric filler. Payback for such an installation can be in the order of weeks.

The weight and production data gathered by in-line checkweighers can also be used to provide valuable information on line efficiencies when linked to a Data Management System. This information can be viewed remote from the line on a central PC or several PC's networked together. A checkweigher can also be linked to a SCADA system (Supervisory Control and Data Acquisition) in order to fully integrate it into a plant automation system.

Checkweighing plays a vital role in protecting the brand and conforming to national weight legislation, combined with a metal detector a combination system can offer not only conformity with weigh legislation vital product safety legislation too in one space saving system.

Finally, remember first class pre and after sales support is key to success. Training at the time of installation, spare parts availability, regional support, cross trained technicians, and support lines must be considered as part of the purchase.

Technical Specification

PVS - performance validation system

Application specific filtering

Dual frequency option for metallised film applications

Various communication options to suit plant integration protocols

Direct transmitter drive to eliminate thermal drift

High field strength to eliminate external interference and deliver the ultimate in noise free detection

32-bit digital signal processing for enhanced contaminant detection

R51 Approved

Aperture heights (mm)

75 (3") 100 (4") 125 (5") 150 (6") 175 (7") 200 (8")

Aperture widths AS1500/5000 (mm)

250 (10") 350 (14") 450 (18") 550 (22")

Aperture widths ASDL (mm)

300 (12") 400 (16") 500 (20") 600 (24")

About Loma Systems

Loma Systems is a world class manufacturer of inspection systems, with installations in over 60 countries and in most of the world's largest food and packaging companies.

Loma Systems holds ISO 9001 certification and has earned a reputation for the consistent quality and advanced technology of its products, the results of a continuous and far-reaching research and development program.

Short lead times, modular design together with our passion for customer service, allow you to:

1. Maximize your production up-time.
2. Maintain your self-sufficiency.
3. Help your customers comply with and exceed consumer and government demands for product safety.



All Loma systems are manufactured to the exacting standards of ISO9001 and supported by a world-wide network of sales and service operations

Loma reserves the right to improve or change specification without prior notice

Finish:	304 stainless steel with bead blast finish	
Typical Line Height:	900mm ± 75mm	35" ± 3"
Typical System Length:	2,100mm	83" (with standard reject)
Transport Types:	PWT - see AS ^{1500/5000} data sheet Drag link - see ASDL data sheet	
Maximum Product Height (Metal Detector):	165mm	6.5"
Supply Voltages:	110 or 230V/1ph/N+E 50 or 60Hz	
Air Supply:	5 to 8 bar	80 to 100 psi
Standard Reject Options:	Air Blast, Pusher, Diverter	
Environment:	IP55/IP66	NEMA12/4X
Belt type:	Flat (food quality) belt	
Standard inclusions:	Variable speed - PWT only, Pack pitch monitor, Adjustable feet, Reject bin (Europe), Printer (Europe)	
Options:	Variable speed - ASDL, Servo feedback - for filler control, Serial Link, LomaNet, Ethernet. Super ruggedized hose - down specification, Reject bin full alarm, Reject confirmation alarm	

Typical System Drawing

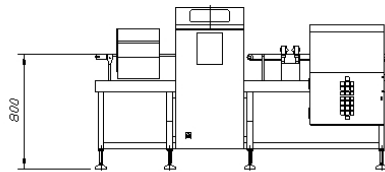
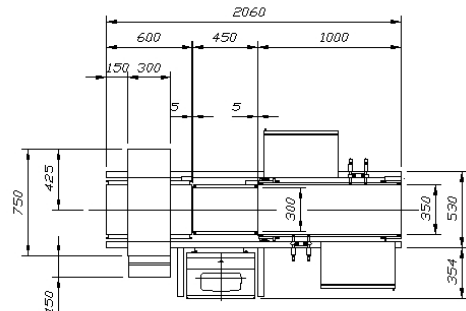

UK Loma - Cintex Southwood, Farnborough Hampshire, GU14 0NY England tel +44 1252 893300 fax +44 1252 513322 e-mail sales@loma-cintex.com	USA Loma Systems 283 East Lies Road Carol Stream, Illinois 60188 USA tel +1 800 USA LOMA tel +1 630 588 0900 fax +1 630 588 1394 e-mail sales@loma.com	Canada Loma Systems Canada 333 Wyecroft Road Oakville, Ontario, Canada tel +1 800 387 7987 tel +1 905 842 4581 fax +1 905 842 3460 e-mail: lomacanada@loma.com	China Spectris China Ltd Unit 101 XinAn Plaza Building 13 No 99, Tianzhou Road Shanghai 200233 PR China tel +86 21 611 33888 fax +86 21 611 33788 e-mail: stevenfang@spectris.com.cn	France Loma - Cintex 120 rue Jean Jaurés 92300 Levallois Perret France tel +33 1 55 69 57 78 fax +33 1 55 17 43 31 e-mail: info@loma-cintex.com	Germany Loma - Cintex Vahrenwalder Straße 269A 30173 Hannover, Germany tel +49 511 9666 811 fax +49 511 9666 812 e-mail: info@loma-cintex.com	The Netherlands Loma - Cintex Panoverweg 22 5705 HR Helmond, Netherlands tel +31 492 573 573 fax +31 492 573 570 e-mail: info@loma-cintex.com	Czech Republic Loma - Cintex U Lomy 1069, 334 41 Dobruška tel +420 377 183811 fax +420 377 183820 e-mail: info@loma-cintex.com
---	---	--	--	--	--	--	--